

MAC motor® - 50 to 134 W - the complete motion solution for lower power ratings

*Brushless servo motor with integrated controller
- everything in one unit, except power supply.*

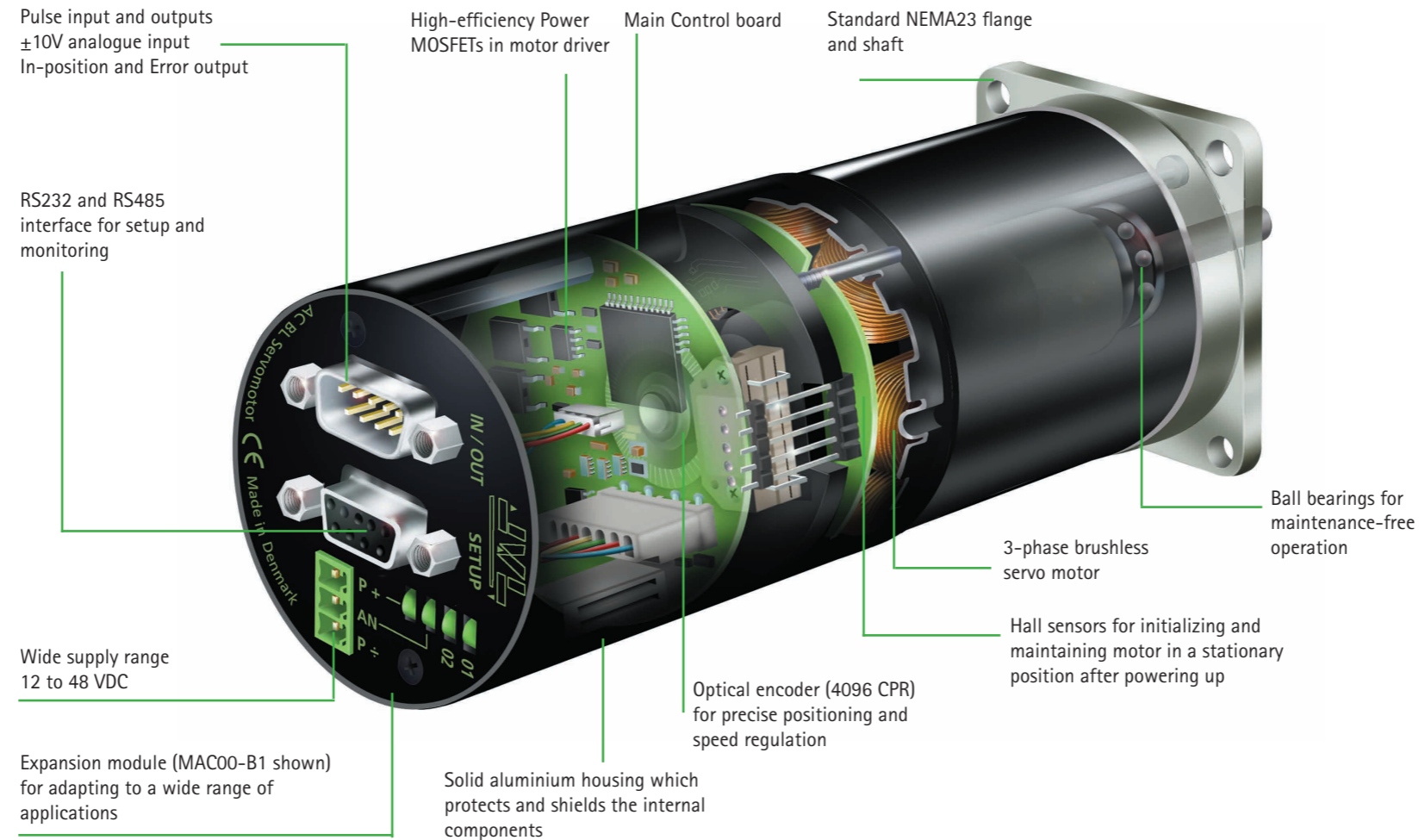

The major advantages of the MAC motors are:

- High performance
- Cost effective
- Decentral intelligence
- Quiet and maintenance-free operation
- High efficiency
- Low operational cost
- Less machine space required
- Low installation cost. Faster installation
- Reduced risk of wiring errors
- Minimum positioning error during operation and halt
- Modular flexibility
- New users can easily set up the system

Main features (basic MAC models)

- Ideal for high-volume applications in harsh industrial environments
- Accepts position and velocity commands sent via 2 serial interfaces
- Genuine AC-servomotor with high torque at high speed
- Pulse and direction inputs make it possible to replace any step motor
- Quadrature output to master controller when used as a ±10V driver
- Switching technology in motor and power supplies
- High-performance serial protocol with addressing facilities
- Easy-to-use Windows program available for installation/set-up

Adapt the motor to your application

The JVL Integrated motors utilize the unique modular concept. Plug-in expansion modules adapt the motor to the application. You can choose connector type: D-Sub, cable glands or M12 connectors, and you can choose freely between Profibus, DeviceNet, CANopen or Nano-PLC control. High Speed and wireless modules add to the selection.

Basic Modules

- | | | |
|---|---|--|
|  | MAC00-CS
Low-cost module, with cable glands and up to 20m cable. Pulse/dir. ±10V | Analog
Pulse I/O
2DO
Cable |
|  | MAC00-B1
General-purpose module with Sub-D connectors: Pulse/Dir, ±10 V, RS232/422/485. LEDs | Analog
RS232
RS485
Pulse I/O
2DO
DSUB |
|  | MAC00-B2
General-purpose module w/Cable Glands. With dual supply. Otherwise same as -B1 | Analog
RS232
RS485
Dual Supp.
2DO
Cable |
|  | MAC00-B4
General-purpose module w/M12 connectors. With USB and dual supply. Otherwise same as -B1 | Analog
RS232
RS485
Pulse I/O
USB
Dual Supp.
2DO
M12 |

Programmable Modules

- | | | |
|---|--|--|
|  | MAC00-R1
Nano-PLC Module w/Sub-D connectors: Stand-alone operation with 8 DI + 4 DO, RS232/485 | Analog
RS232
RS485
Dual Supp.
8DI+4DO
DSUB |
|  | MAC00-R3
Nano-PLC Module w/Cable Glands. Otherwise same as -R1 | Analog
RS232
RS485
Dual Supp.
8DI+4DO
Cable |
|  | MAC00-R4
Nano-PLC Module w/M12 connectors. Otherwise same as -R1 | Analog
RS232
RS485
Dual Supp.
8DI+4DO
M12 |



The complete range of JVL AC servo, integrated MAC motors offers a wide selection of motor sizes that are adaptable to a wide range of applications.



Electronic Brake

Optionally, an electronic brake MAB23X can be mounted on all motors with a NEMA23 flange and 6.35mm shaft. It is useful for holding the motor shaft fixed at power off, or when the motor is used in a vertical application.



IP67 versions are resistant against rough chemicals and are ideal for use in the food processing, pharmaceutical and chemical industries. Watertight sealing is provided by an IP67 Rulon® teflon shaft sealing with very low friction requiring no lubrication. Flange and shaft are made of stainless steel.



Power Supplies

JVL supplies a wide range of power supplies for one or several MAC motors. They range from very simple do-it-yourself kits to large switch-mode supplies.



It should be noted that MAC800 includes a complete 115/230V AC power supply for driver voltage. Only 24 VDC for control circuitry is required externally.

- DSUB**: 9 or 15-pin DSUB connectors. IP42.
- Cable**: Shielded cable up to 20 m. IP67.
- M12**: M12 screw connector. Cable up to 20 m. IP67.
- Dual Supp.**: Position and parameters can be maintained under emergency stop.

MAC motor® - 750 W - the complete solution for larger power ratings

Brushless servo motor with integrated controller
- everything in one unit, including mains power supply.

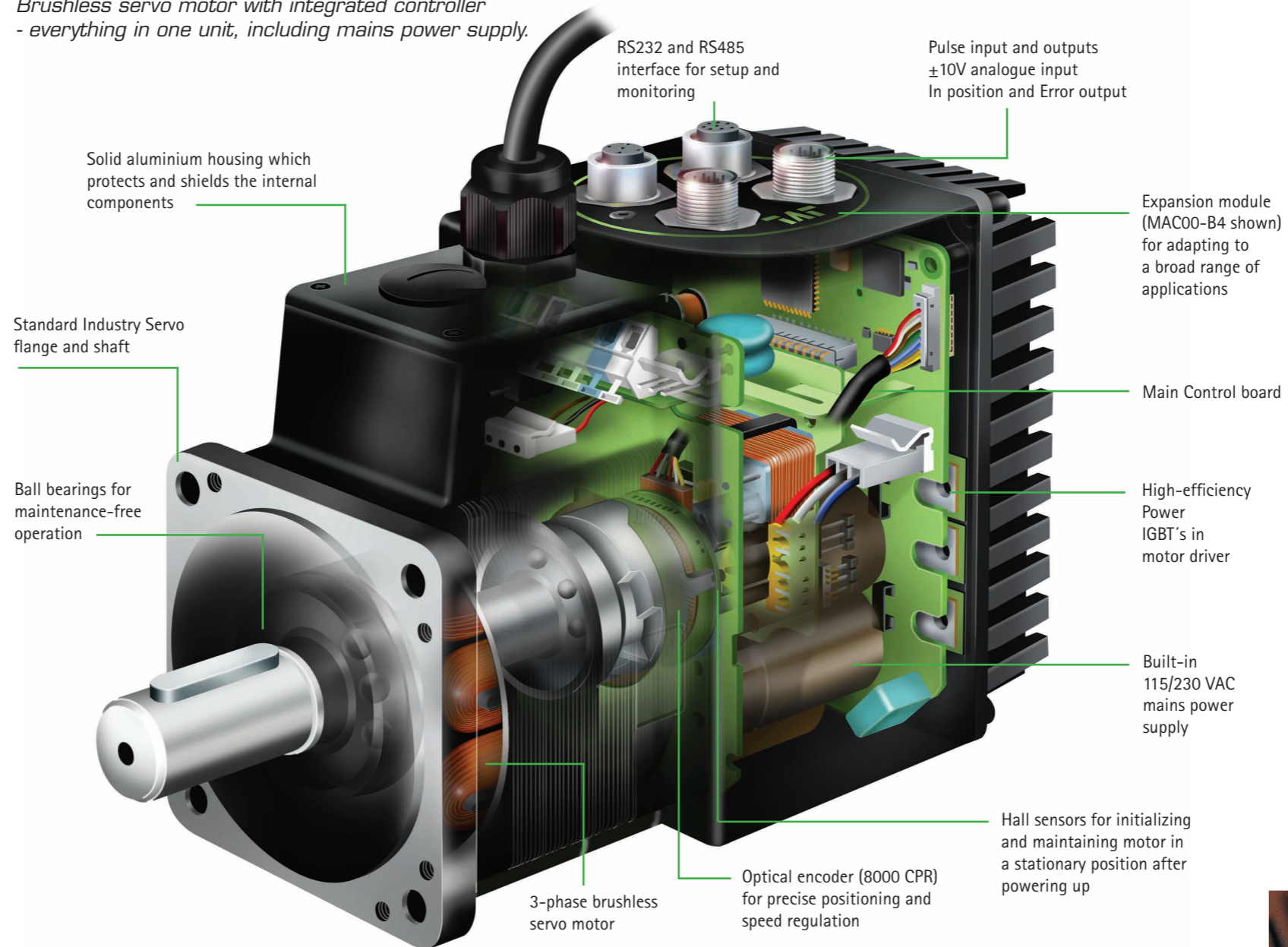

This means that the MAC motor gives you possibilities no other motors on the market can provide. Also important, you only pay for what you need. In addition, if you do not find the features you require, please contact us, and we will develop your own customised module.

FieldBus Modules

MAC00-FC4
CANopen DS301/DSP402 Module w/M12 connectors: Bus, 4 I/O and RS232

- Analog
- RS232
- 4DI/2DO
- Dual Supp.
- Limit +/-
- M12
- CANopen

MAC00-FD4
DeviceNet Module w/M12 connectors: Bus, 4 I/O and RS232

- Analog
- RS232
- 4DI/2DO
- Dual Supp.
- Limit +/-
- M12
- DeviceNet

MAC00-FP2
Profibus Module w/ Cable Glands: Bus, 6 DI + 2 DO + 1 AI and RS232

- Analog
- RS232
- Dual Supp.
- 6DI/2DO
- Limit +/-
- Cable
- Profibus

MAC00-FP4
Profibus Module w/M12 connectors: Bus, 4 I/O and RS232

- Analog
- RS232
- Dual Supp.
- 4DI/2DO
- Limit +/-
- M12
- Profibus

High-Speed Multi-Axis modules

MAC00-FS1
High-Speed 961 kbit Multi-axis Module. RS485 bus w/up to 255 axes.

- Analog
- RS485
- Dual Supp.
- 4DI+2DO
- DSUB

MAC00-FR4
High-Speed Multi-axis Module. For SoftNC (IEC61131-3) Soft PLC. Sync. 3D movements.

- Analog
- RS485
- Dual Supp.
- 2DI+2DO
- M12

Wireless Modules

MAC00-FB4
Bluetooth Module w/M12 connectors. Controlled from a PC, PDA, Smart Phone...

- Analog
- Pulse I/O
- Dual Supp.
- M12
- Wireless

- Analog** ±10V for speed or torque control or 24V home switch.
- Pulse I/O** RS422 balanced inputs for pulse/direction incremental signals or encoder output.
- Limit +/-** 2 of the inputs can be used as negative and positive limit switch inputs. = Optocouplers.



Gearboxes
A wide range of planetary and backlash free gearboxes can be provided for all the MAC motors.



Cables
Use our ready-made cables - avoid incorrect connections and achieve fast and easy installation.



Built-in Brake
For applications in which motor position must be maintained at power-off, or for use in vertical applications, the 750W MAC motor can be supplied with a built-



MAC800 motors are UL approved

in brake. The holding torque is 3.2 Nm. The brake is automatically activated at power-off, during a fatal error or a via a software command.

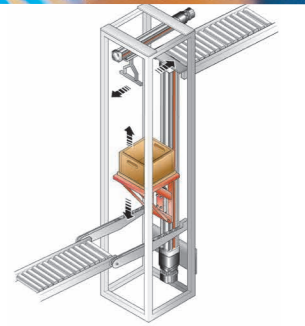

Material Handling Systems
vertical and horizontal transfer movements

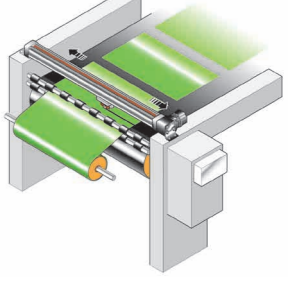

Slitting Machines. High-speed traverse applications for slicing materials

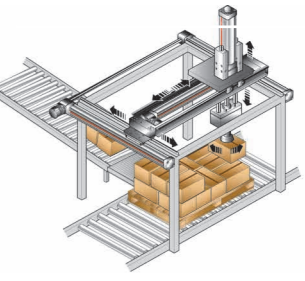

Auto Handling. High-speed pick and place movements

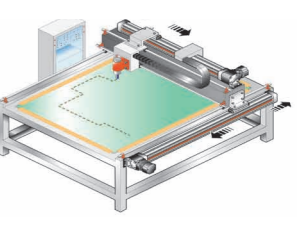

Profile Cutting Machines. Complex movements of water jets and laser cutters

Other applications

- Replacement for pneumatic solutions
- Replacement of step motors, offering much faster response and speed
- Conveyor systems
- Printing machines
- 3-D and XY tables
- Replacement for frequency inverters
- ±10V speed/torque driver for external controllers
- Screw and toothed belt pick and place robots
- Labelling dispensers

Software

JVL delivers the software that you need!

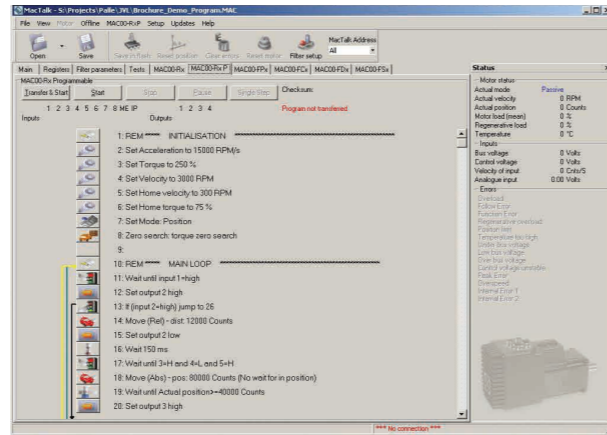
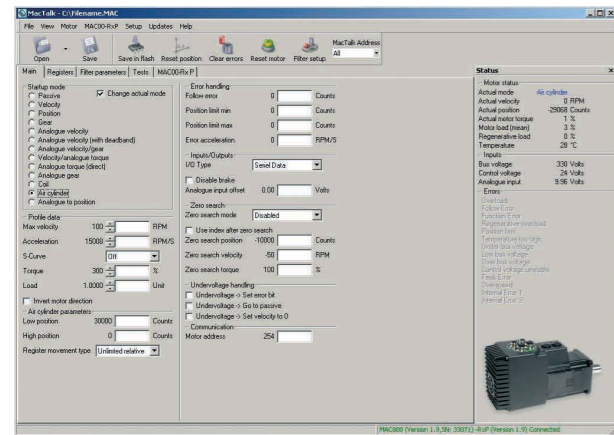

MacTalk

For setup, monitoring and diagnostics, MacTalk is the preferred choice for most users.

Although advanced functionality is included, all operations are very intuitive and easy to use.

MacTalk allows you to adjust all vital parameters and save them in a file – or load them from a file. It is also possible to monitor parameters and motor status in real time.

When commissioning a system, MacTalk even provides a convenient way to test and adjust your system. You can easily set up a test sequence, and then adjust parameters like velocity, acceleration and torque. It is possible to select the distance moved and the delay between the moves.

The more advanced 6th-order filter used in MAC motors, instead of a simple PID loop, is easily adjusted.

A nice feature is the Update function: if your PC is connected to the Internet, you can update the MacTalk software itself – and even the servo system's firmware can be updated, both the driver and the expansion module. Once bought, MacTalk will stay "fresh" – always including the latest functionality.

Graphical Programming

Nano PLC MAC00-Rx module can be programmed from MacTalk using user-friendly, icon-based commands in a graphical programming environment. With 8 Inputs and 4 Outputs, all 5-24VDC, and one $\pm 10V$ analogue input, a small PLC system can be programmed. It is register-based with different kinds of relative or absolute movements, Jump and IF commands, timers and other functions. It is possible to request input conditions and set outputs. All registers and parameters in the MAC motor can be accessed and changed if required.

OCX software

If your application is controlled by a PC, you might prefer JVL's OCX software.

The OCX (OLE Custom Controls – also known as ActiveX Controls) enables applications to be easily developed in for example:

- Visual Basic
- Visual C++
- Visual .Net
- Delphi
- Borland C++ Builder
- LabView
- Excel

or any other environment supporting OCX controls.

Specifications

	MAC050	MAC095	MAC140	MAC141	MAC800-D2	MAC800-D5	Unit
Technical specifications							
Supply voltage	12-48VDC	12-48VDC	12-48VDC	12-48VDC	(115)/230VAC	(115)/230VAC	
Av. current@rated load	1.2@4 8VDC	2.4@48VDC	3.2@48VDC	3.2@48VDC	(10)/5	(10)/5	ARMS
Peak supply current (Typical)	3@48VDC	6@48VDC	9@48VDC	9@48VDC	(30)/15	(30)/15	ARMS
Speed range (nominal)	0-4000	0-4000	0-4000	0-2700	0-3000	0-3000	RPM
Rated power	46	92	134	134	746 (1hp)	746 (1hp)	W
Cont. torque	0.11/15.6	0.22/31.2	0.32/45.3	0.48/68	2.38/337	2.38/337	Nm/oz-in
Peak torque	0.32/45.3	0.62/88	0.9/127.5	1.59/225.2	7.14/1011	7.14/1011	Nm/oz-in
Rotor inertia	0.075/0.00106	0.119/0.00169	0.17/0.00240	0.23/0.00327	0.91/0.01289	1.13/0.016	kgcm ² /oz-in-s ²
Physical dimensions	Ø58.7x111.2	Ø58.7x131.5	Ø58.7x150.5	Ø58.7x172	80x111x174	80x111x207	mm inch
Weight (without exp. module)	0.6/1.32	0.85/1.87	1.1/2.42	1.33/2.93	3.5/7.7	4.3/9.46	kg/lbs
Protection class	IP42		IP42(IP67 optional)		IP55 (IP65 on request)		

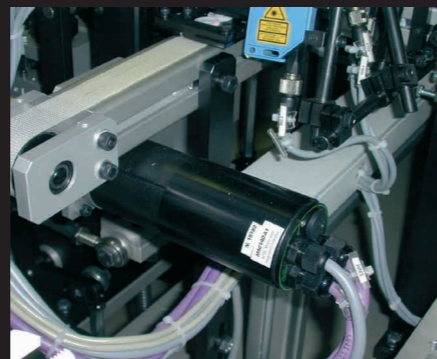
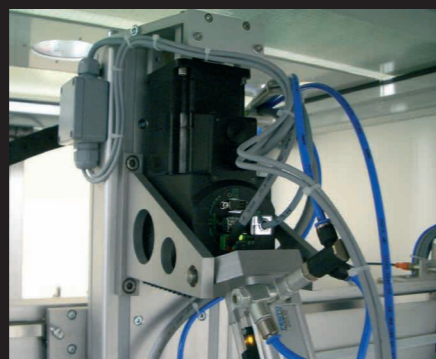
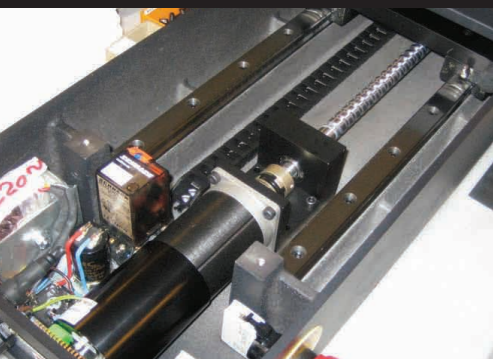
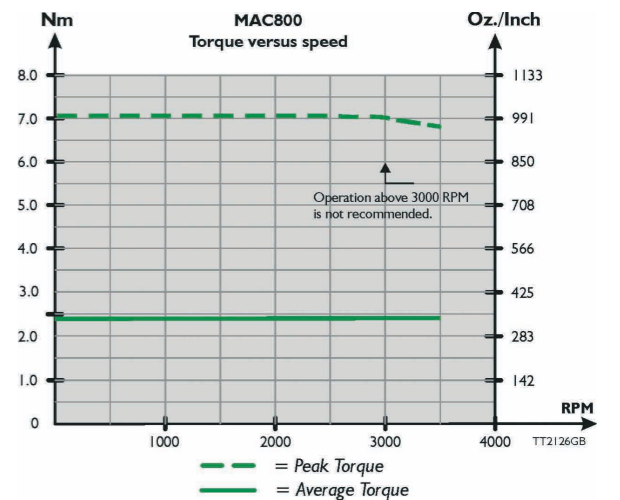
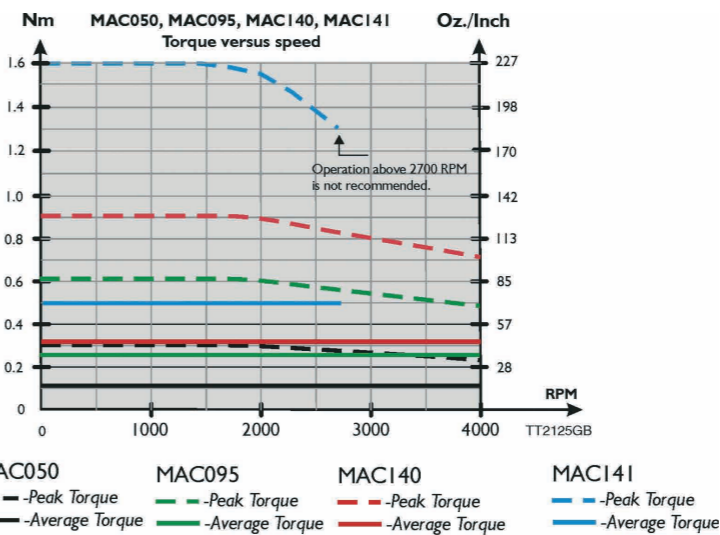

JVL Industri Elektronik A/S

JVL Industri Elektronik A/S is a modern company, located in Birkerød, just north of Copenhagen. The up-to-date R&D and production facilities of JVL employ only the latest technology for the development and production of electronic controls for step- and servo motors. More than 50% of the staff are engineers with a very high degree of experience and competence in the field of motion control. We can therefore offer a product programme that includes all the necessary units and components to build up a complete motor control system.

JVL is represented throughout Europe and Asia by independent distributors, and in the USA by a sister company, JVL International ApS. In the U.K. we have our own office, JVL UK Ltd. All distributors are carefully selected by JVL to have the necessary knowledge and experience to help our customers in the best possible way with their choice of motion control components.



...when motors must be controlled

JVL Industri Elektronik A/S
 Blokken 42
 DK-3460 Birkerød, Denmark
 Tel: +45 4582 4440
 Fax: +45 4582 5550
 E-mail: jvl@jvl.dk
 www.jvl.dk

LC0016-01GB

MAC motor® - the complete solution



Save Money and Troubles

Formerly building up a motion control system was a complicated affair involving many components:

- PLC
- Indexer/controller
- Driver
- Motor with Encoder and Hall sensor
- A lot of cabling to connect all these items.

-and finally complex software that had to be programmed properly.

It required a lot of expertise to make the system function correctly, and installation was very time consuming and introduced many sources of potential faults. Electrical noise from the cables carrying the high motor currents added to the problems.

JVL has reduced these problems to a minimum with the introduction of the Integrated MAC motor to the motion control market.

In these motors the Indexer/controller, Driver, Encoder and Hall sensor are all built together with the motor in one compact unit.

A software package, MacTalk, makes set-up extremely easy, and expansion modules mount directly into the motor housing to adapt the motor to almost any application.

By investing in a modern integrated MAC motor from JVL, you achieve the following benefits:

- Reduced material costs. Because the driver and controller are in the motor, most cabling to a control panel is eliminated.
- Reduced labour costs. With cabling eliminated, assembly time is greatly reduced.
- Better quality & reliability. Fewer connections, less wiring.

- Ease of service. Because all electronics are self-contained, you simply replace the motor.
- Double supply facility to ensure that position and parameters are maintained after emergency stop.
- Switching noise from the drive due to commutation is contained in the motor.
- Reduced setup time. 6th-order digital filter requires only one tuning parameter for load or reflected inertia.
- OEM cost savings. Modular approach means you only pay for the functionality required.

A new way of earning money The integrated servo motors

Brushless servo motors
with integrated controller



Previous system build-up

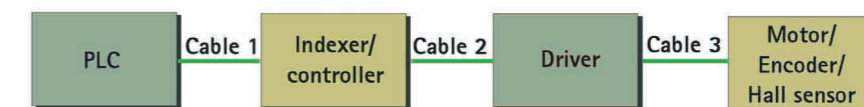

Modern system build-up

